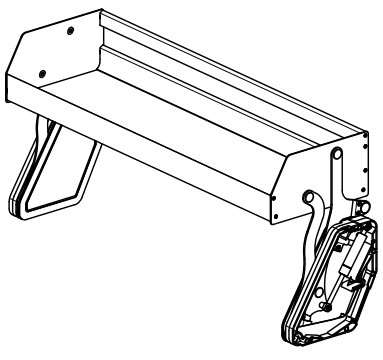
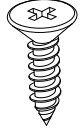
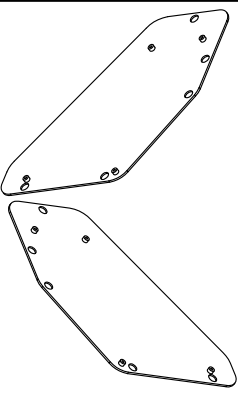
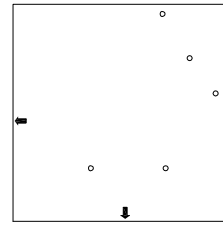
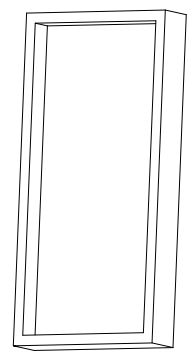

ASSEMBLY INSTRUCTION

1 Components:

Single Lifter Components

A 1set	B 10Pcs	C 2Pcs	D 1Pcs	E 1Pcs
				

2 Assembly steps:

screw B to fix A on side board

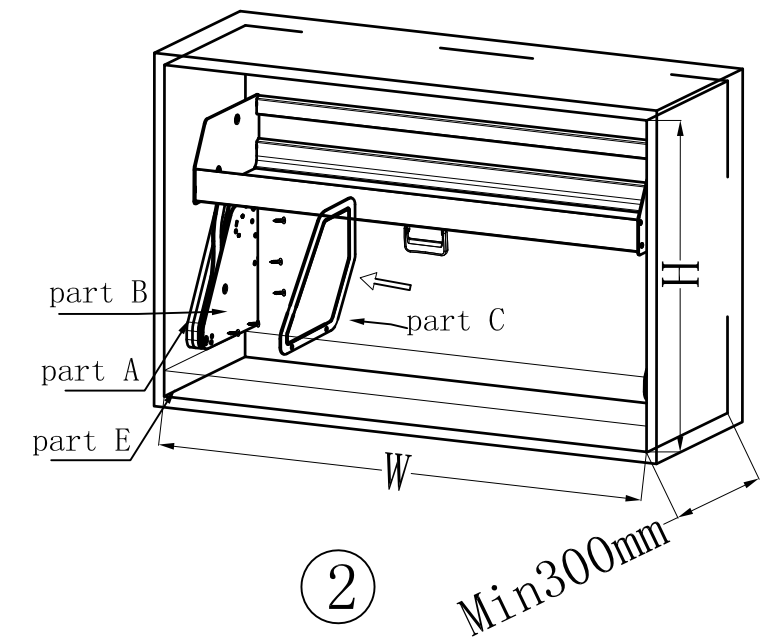
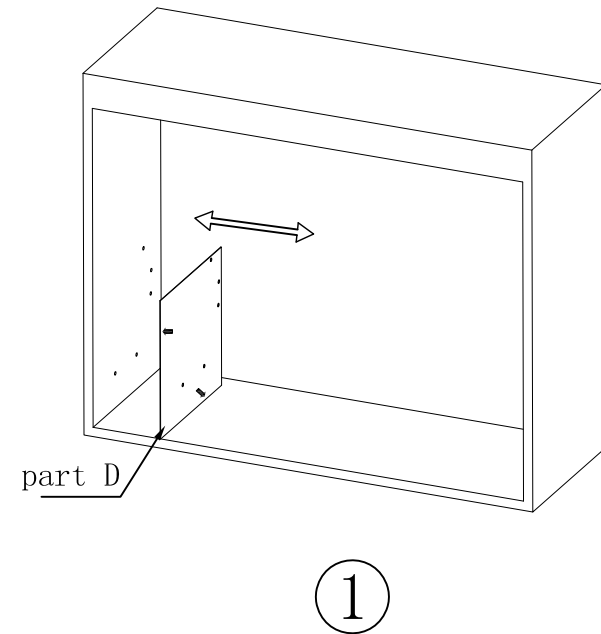

(Double lifter-second layer assembly)

Second layer Components

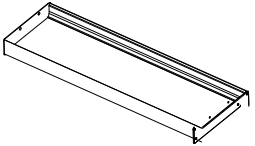
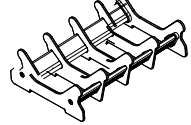
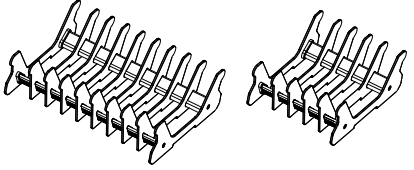
F 1set	G 2Pcs	H 1Pcs	I 4Pcs
	(900, 800, 700mm) 2PCS (600mm) 1PCS 	(900, 800mm) (700, 600mm) 	M4*55 