

Assembly Instruction

Specification (W*D*H) mm	Applicable cabinet width mm
564*240*571.5mm	600
764*240*571.5mm	800
864*240*571.5mm	900

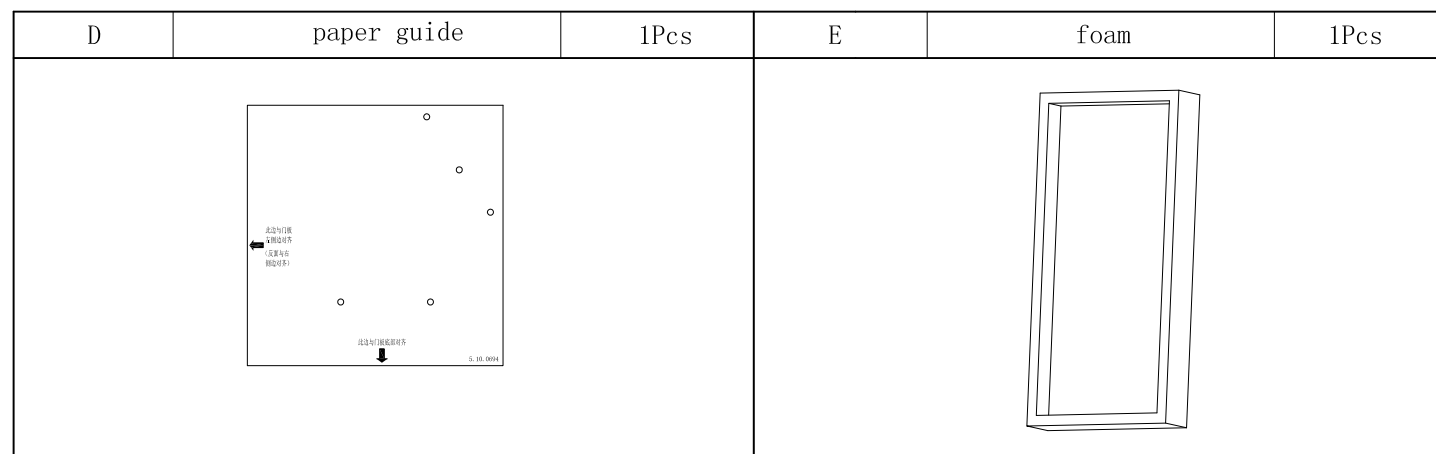
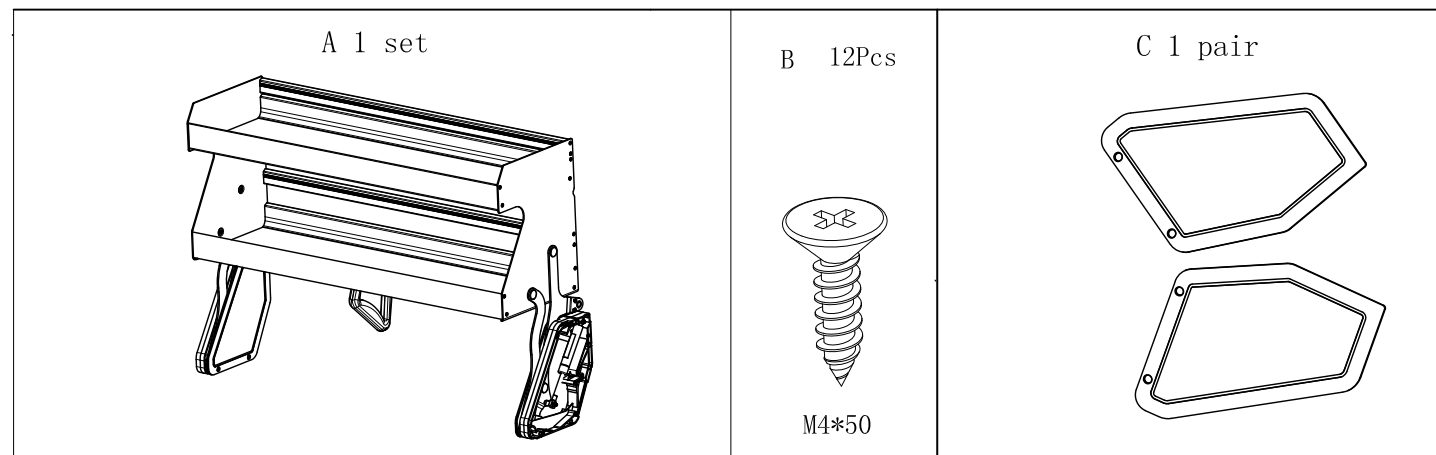

Installation step:

1. drill screw holes according to paper guide
 2. fix product onto side board with screw B, and cover C

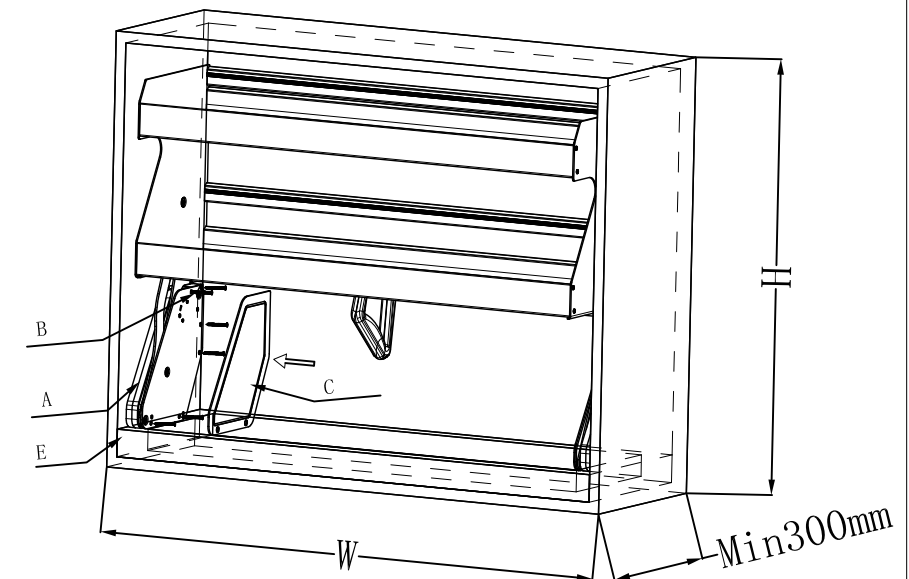
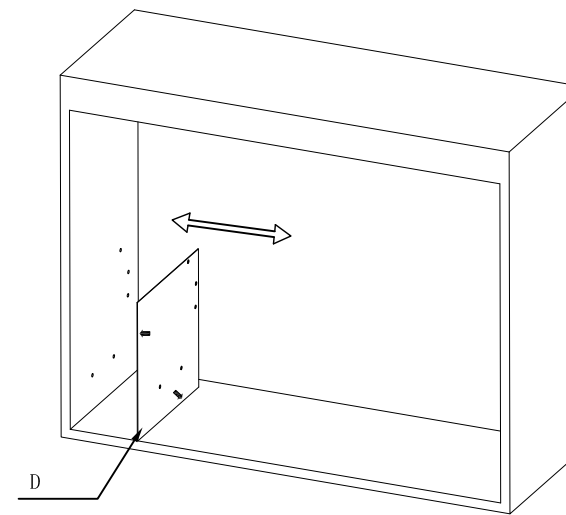

3. Finish and check the function.

